

SATO PITLINER

Need to construct a latrine? The SATO Pitliner has been designed to be sturdy, quick-to-assemble, and easily transported.

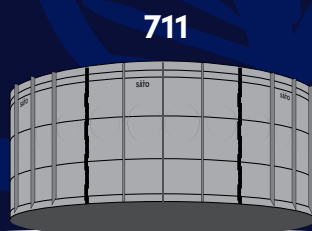

711

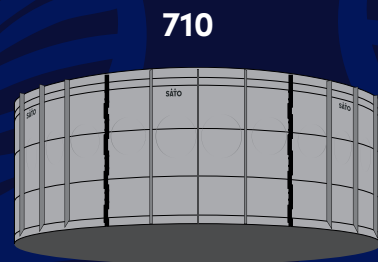

710

BENEFITS

- Individual panels are lightweight and stack for compact packaging ensuring easy transport and handling. This makes the pitliner suitable for use in difficult to access site locations
- Designed and tested to hold back soil pressure
- Includes a non-perforated top layer to prevent excess rainwater from entering the pit
- Optimal perforations for leach pit promote excellent drying of pit contents while preventing excess soil or pests from entering the pit
- The interlocking panels click together to create a rigid pit lining quicker than the conventional brick construction
- Does not require any additional tools, materials or skilled labour (e.g. brick laying) to install the pitliner
- Available in two sizes depending on the diameter of the pit required

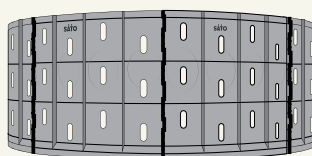

X5 PANELS

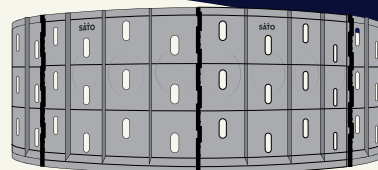

X6 PANELS

SPECIFICATION

SATO710: Plastic Pit Liner with Internal Diameter of 1000 mm for leach pit applications. Comes with eighteen (18) panels. Six interlocking panels to form a ring and three rings stacked for quick and easy assembly. Tested to withstand soil pressure in various soil conditions and rain patterns in India and Uganda.

SATO711: Plastic Pit Liner with Internal Diameter of 830 mm for leach pit applications. Comes with fifteen (15) panels. Five interlocking panels to form a ring and three rings stacked for quick and easy assembly. Tested to withstand soil pressure in various soil conditions and rain patterns in India and Uganda.

SATO
A BETTER LIFE.
EVERY DAY.

Installation guide
<https://we.tl/t>
For the full SATO portfolio
Download our Brochure here
<https://brochure.tl/t>



PITLINER

TECHNICAL SPECIFICATIONS AND SHIPPING DETAILS

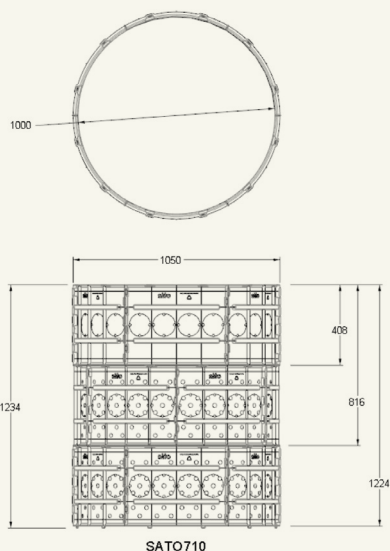

SATO710

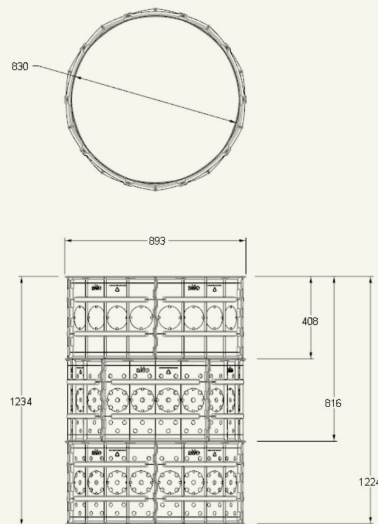

SATO711

Skus	SATO710	SATO711
Panels:	Total 18 Panels 6 pcs of solid panel 12 pcs of perforated panels	Total 15 Panels 5 pcs of solid panel 10 pcs of perforated panels
Dimensions:	1 Panel: 418x541x90 mm (LWH)1234 x 1050mm OD (Ø1000mm ID)1 Box (18 Panels): 430x555x475 mm (LWH)	1 Panel: 418x541x90 mm (LWH)1234 x 893mm OD (830mm ID equivalent) 1 Box (15 Panels): 430x555x410 mm (LWH)
Weight:	1 Panel: Solid- 706 gm; perforated- 684 gm 1 Box (18 Panels): 12.5kg	1 Panel: Solid- 706 gm; perforated- 684 gm 1 Box (15 Panels): 10.5kg
Loading capacity:	Single Panel: 150 kg	Single Panel: 150 kg
Colour:	Black	Black
Material:	Polypropylene	Polypropylene
Shipping details:	Supreme India Silafrica Tanzania	Supreme India Silafrica Tanzania
Lead time:	Min 2 weeks after order placed	Min 2 weeks after order placed
MOQ:	Min 120 units	Min 120 units
Availability:	India: June 24 Tanzania: July 24	India: June 24 Tanzania: July 24
Price:	On request	On request

PAYMENT

100% in advance. All POs to be addressed to LIXIL 24F, 1 Chome-1-1 Nishishinagawa, Shinagawa City, Tokyo 141-0033



Please call our Customer Experience Centre:

Kenya 0800 722 233
Nigeria 0800 123 5400
Uganda 0800 200 457
Tanzania 0800 120 076
Rest of Africa +254 800 722 233

Monday to Friday between 9am-6pm
Monday to Friday between 9am-6pm
Monday to Friday between 9am-6pm
Monday to Friday between 9am-6pm
Monday to Friday between 9am-6pm
or Saturday between 9am and 1pm

Email: sato@lixil.com

SATO

**A BETTER LIFE.
EVERY DAY.**